

PART NO.	"A"±.020	"B"±.020	STUD THREAD "S"	INSERT THREAD "I"	FIG. NO.	REF. LOAD AT 15% DEFLECTION LBS (KG)
QM1	7/16 [11.1]	7/16 [11.1]	#6-32 X 1/4	---	1	8 [4]
QM1T				#6-32 X 3/16	2	5 [2]
QM2T				#6-32 X 3/16	2	7 [3]
QM3	1/2 [12.7]	9/16 [14.3]	#8-32 X 3/8	---	1	9 [4]
QM3T				#8-32 X 3/16	2	8 [4]
QM4		---		1	15 [7]	
QM4T		#8-32 X 3/16		2	28 [13]	
QM5	3/4 [19.1]	1.0 [25.4]	#1/4-20 X 1/2	---	1	43 [20]
QM7	9/16 [14.3]	1/2 [12.7]	#10-32 X 3/8	---	1	3 [1]
QM7T				#10-32 X 3/16	2	10 [5]
*QM8	SEE DRAWING FOR DIMENSIONS				3	12 [5]

FIG 1.

FIG 2.

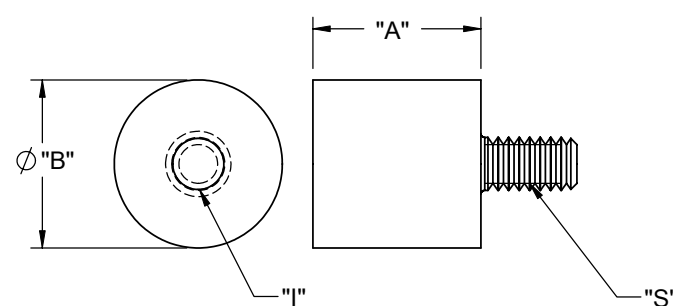
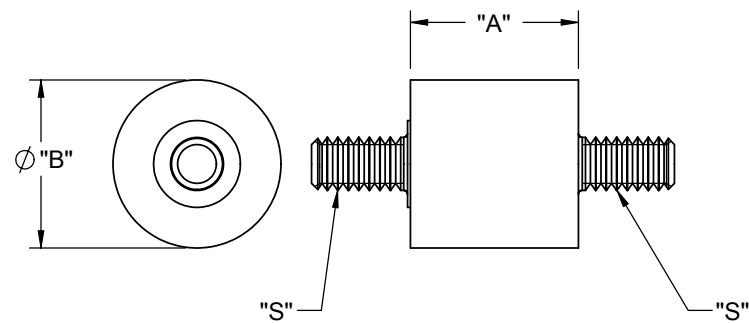

*FIG 3.

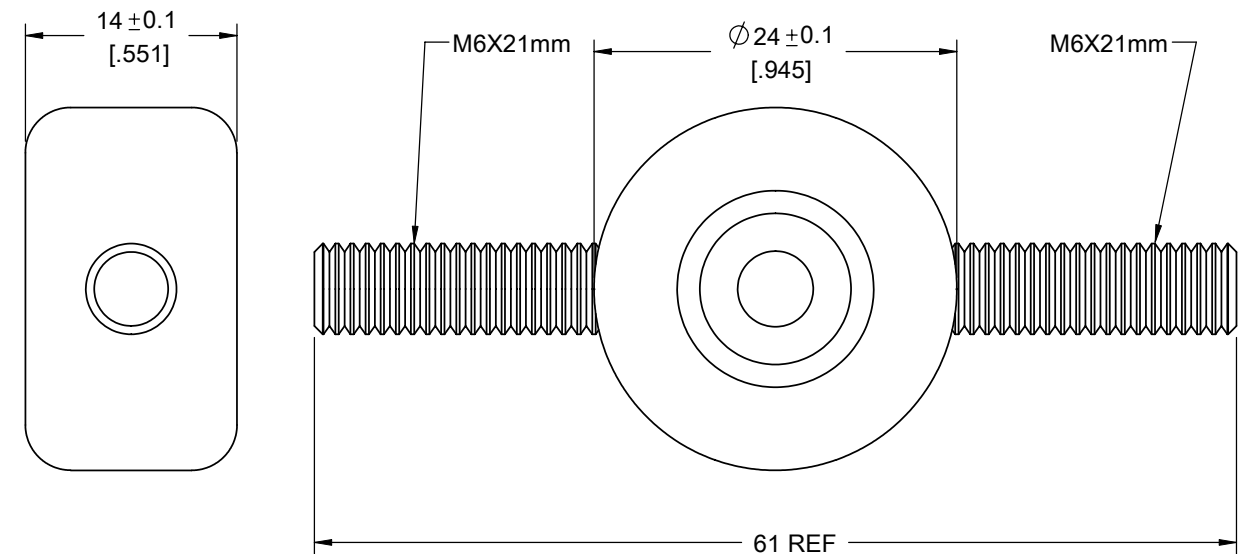

- NOTES:
1. MATERIAL: NEOPRENE RUBBER, 40 DUROMETER (RMS-241)
 2. COLOR: BLACK
 3. THREADED METAL INSERT AND STUD: 1010-1020 STEEL (RMS-242)
PLATING: YELLOW CHROMATE OVER ZINC PLATE (RMS-274)
 4. THREADED METAL INSERT MAY BE BLIND CUP, OR THROUGH-NUT
 - *5. MATERIAL: IIR, SHORE 55A DUROMETER (RMS-360). COLOR: BLACK.
METAL STUD: BRASS (RMS-349).
PART DESIGNED IN METRIC.
 6. ALTERNATE UNITS FOR REFERENCE ONLY.

REV.	DESCRIPTION	ENGR.	DATE
I	SEE CO 200045 FOR CHANGES	SK	10/02/07
H	SEE CO 200041 FOR CHANGES	SK	09/28/07
G	SEE ECN #1326 FOR CHANGES	SK	05/16/07
-	SEE ENGINEERING FOR REVISIONS A-F	---	-----

TITLE: QUIET MOUNT SPACERS				DWG IN IN [MM]		FINAL	
CREATED USING SOLIDWORKS	FILE #: QM	DWN: SK	APP: SK	PART #			
TOLERANCES UNLESS NOTED .XX=±.010 .XXX=±.005 FRAC.=±1/64 ANG.=±1°	SHEET: 1 OF 1	SHEET SIZE: B	DT: 05/16/07	CHKD: DZ	SEE TABLE		
RE: RICHCO, INC.	RICHCO, INC. ENG@RICHCO-INC.COM (773) 539-4060		PRINT TYPE		CA		